

MASSIMO 3 AXIS CNC

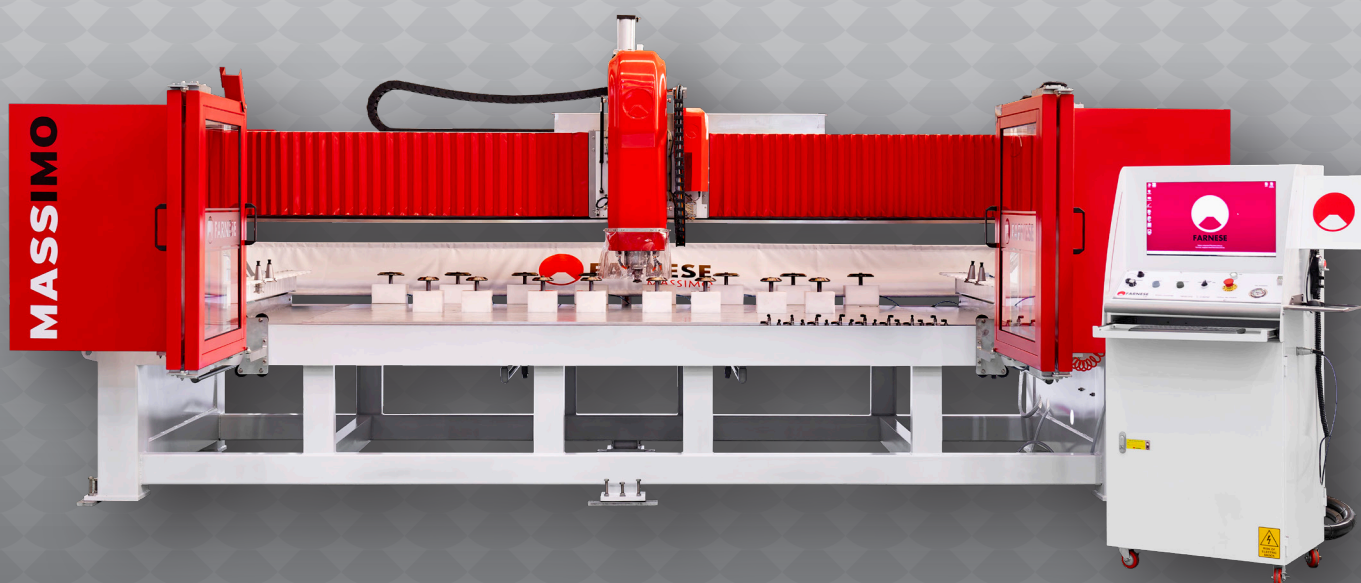

DESIGN FEATURES

A MID SIZE 3 AXIS CNC

SIMPLE, EASY TO USE SOFTWARE

TOUCH SCREEN CONTROL

INTERNAL AND EXTERNAL POLISHING AND PROFILING

TAGLIO CAD/CAM SOFTWARE INCLUDED

CAD/CAM SYSTEM FOR USE WITH TEMPLATES AND DXF FILES

RETRACTABLE CLAMPING PISTONS FOR UNDERMOUNT PROCESSING

AUTOMATIC TOOL CHANGE WITH 28 STATIONS

Founded in 2000 by the Farnese family, **Farnese Australia** are designers and manufacturers of stone cutting and polishing machinery in Australia. With an international reputation and decades of combined professional experience, and expertise, in both the stone industry and the local stone machinery manufacturing industry, Farnese are the first choice for stone fabricators. They continue to dominate this field in Australia and overseas with precision and innovation.

The team at **Farnese Australia** have the experience it takes to design, install and maintain the equipment needed in your industry.

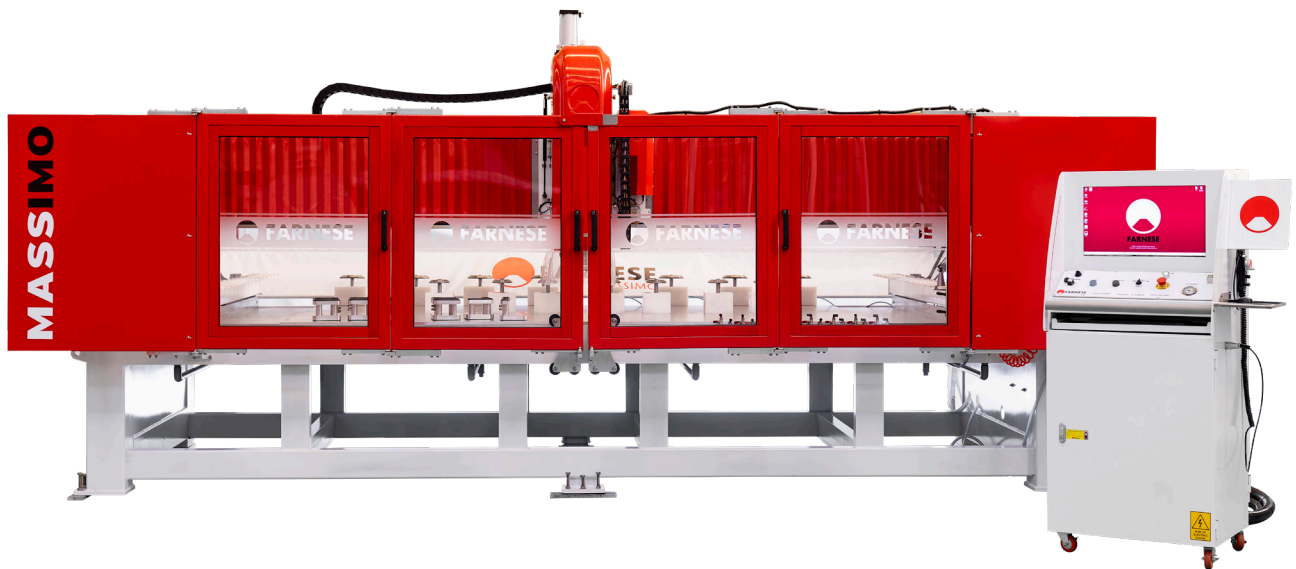

The new **Massimo** from Farnese Australia is a mid-size CNC, designed to fit into our range between the smaller Alexia and the full size Legend. This very capable machine can take care of undermount cutouts, drill holes, produce drain grooves and flat drain board recesses, along with both internal and external edge profiling and polishing.



DESIGNED FOR FUNCTION, BUILT TO LAST.

Of course, like all Farnese machines, we make these features simple to use. A powerful, yet user friendly interface makes operating the new Massimo a breeze. The MS Windows based operating system is intuitive and easy to understand, even for relatively inexperienced operators. It comes pre-loaded with common sink templates from brands including Oliveri, Franke, Clark and Blanco.



Additional shapes can be created easily using the parametric section, further extending the machine's capabilities. The machine also comes equipped with Taglio CAD/CAM Software, dedicated for stone processing.

For 35 years Taglio Software has been developing its own software, providing innovative technologies with very high precision, efficiency and quality. The software provides a series of CAD/CAM applications essential for design and for the processing of complex works on stone, via a DXF File.

With the aid of Digital Measuring Devices, you will be able to measure a job directly on site, create the drawings on your preferred CAD and send them directly to the Massimo for processing, saving valuable time and reducing errors.

Edge profiles like bullnose, lambstongue, etc are easily achievable with the addition of optional tool sets.



Like the Alexia, this machine also features retractable clamping pistons in the middle of the table for easy processing of undermounts. The Massimo has automatic tool changing with 28 tool stations.

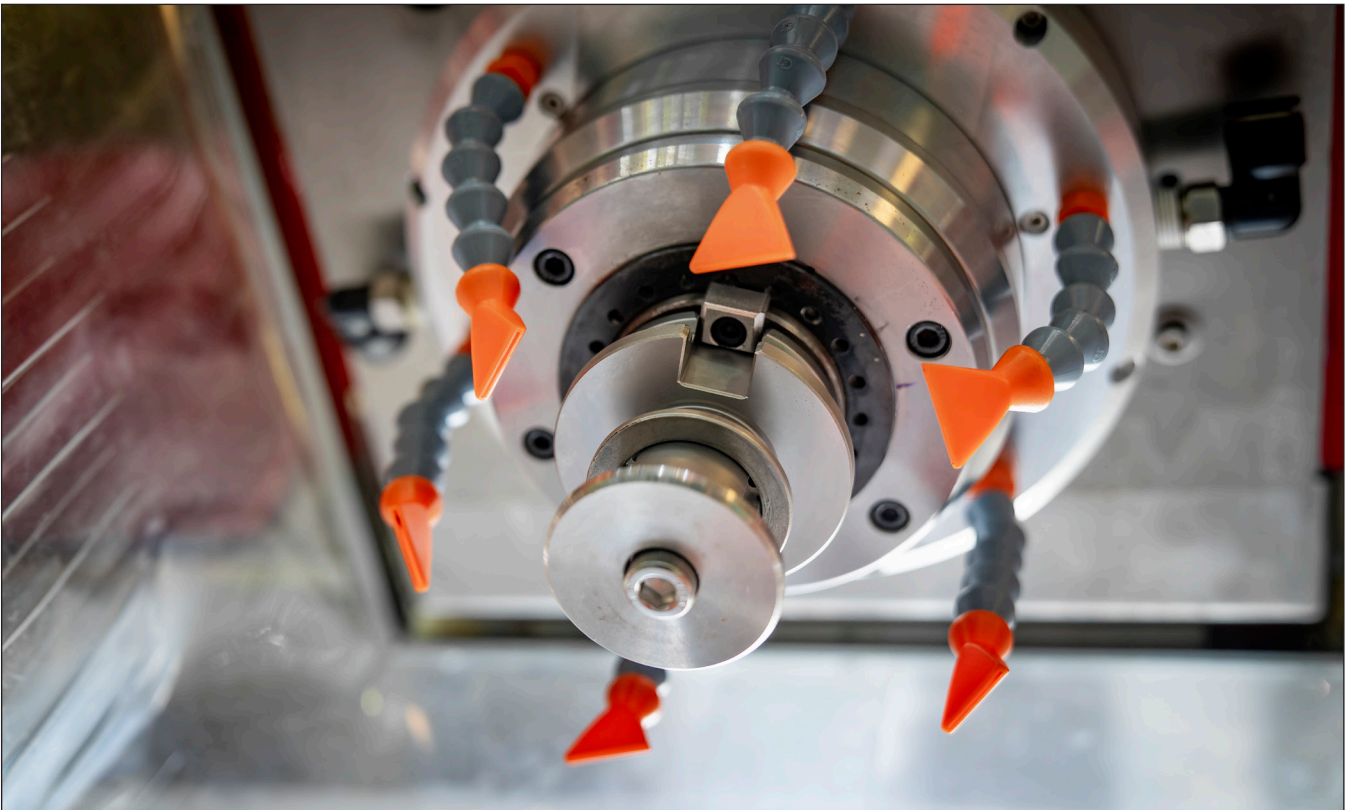



Summary of Features

- Mid size 3 axis CNC
- Touchscreen control panel
- Easy to use interface and software
- CAD / CAM system
- Taglio Software - Advanced CAD/CAM Software solution
- After sales service
- Local supply of spare parts
- Remote access for troubleshooting help

MASSIMO 3 AXIS CNC

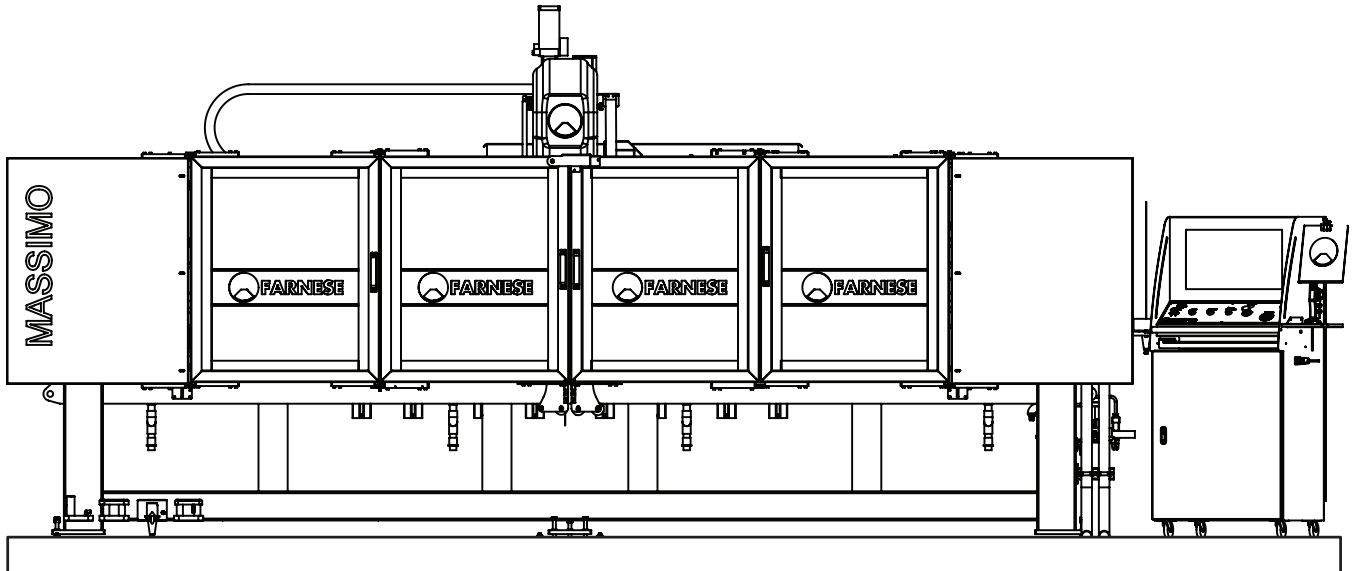

TECHNICAL SPECIFICATIONS

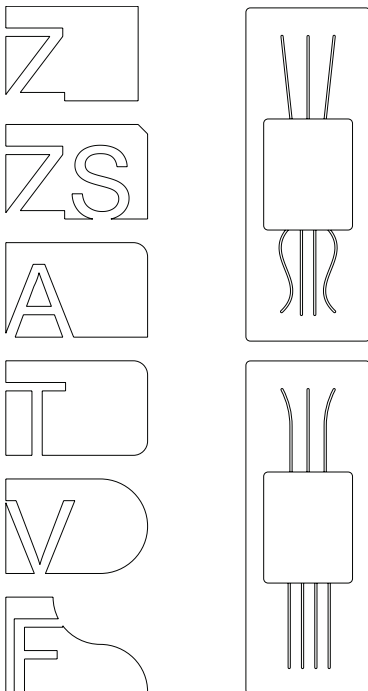

DIMENSIONS OF INSTALLED MACHINE	METRIC	IMPERIAL
LENGTH	5784 mm	227.7 in
DEPTH	3010 mm	118.5 in
HEIGHT	2753 mm	108.4 in
WEIGHT	3500 kg	7700 lb

MAX SIZE OF SLAB	METRIC	IMPERIAL
LENGTH	3200 mm	126.0 in
WIDTH	1600 mm	63.0 in

FEATURES & FEEDS	METRIC	IMPERIAL	
X STROKE (CROSS TRAVEL STROKE)	4200 mm	165.4 in	
Y STROKE (LONG TRAVEL STROKE)	1780 mm	70.1 in	
Z STROKE (HEAD UP AND DOWN)	200 mm	7.9 in	
AIR PRESSURE (WORKING)	7 bar	102 psi	
AIR SPRESSURE (CONSUMPTION)	350 l/min	12.4 cfm	
WATER (CONSUMPTION)	CLEAR	6.5 l/min	1.7 g/min
	RECYCLED	50 l/min	13.2 g/min
MAGAZINE	YES / 28 POS	YES / 28 POS	
BACK CLAMPS	YES	YES	
FRONT CLAMPS	YES	YES	
AUTOMATIC GREASING	YES	YES	
MICROSOFT WINDOWS COMPATIBLE	YES	YES	
AUTOMATIC TOOL CHANGER	YES	YES	
HANDWHEEL	YES	YES	
MAIN SPINDLE POWER	6.6 kW	8.8 hp	
MAIN SPINDLE SPEED (MIN & MAX)	500 - 12000 rpm	500 - 12000 rpm	
POWER REQUIRED	400v 3ph 50Hz	208v 3ph 60Hz	
	20A+ Neutral	40A	

CONNECTIONS REQUIRED (SUPPLIED BY CUSTOMER)
POWER, WATER, COMPRESSED AIR

TOOLING | CONSULT YOUR LOCAL FARNESE DEALER FOR ANY TOOLING REQUIRED

Owing to the constant updating of our designs, descriptions and technical data shown in our drawings and folders are not binding. Possible alterations deemed by the makers as convenient will be effected at any time without previous notice.

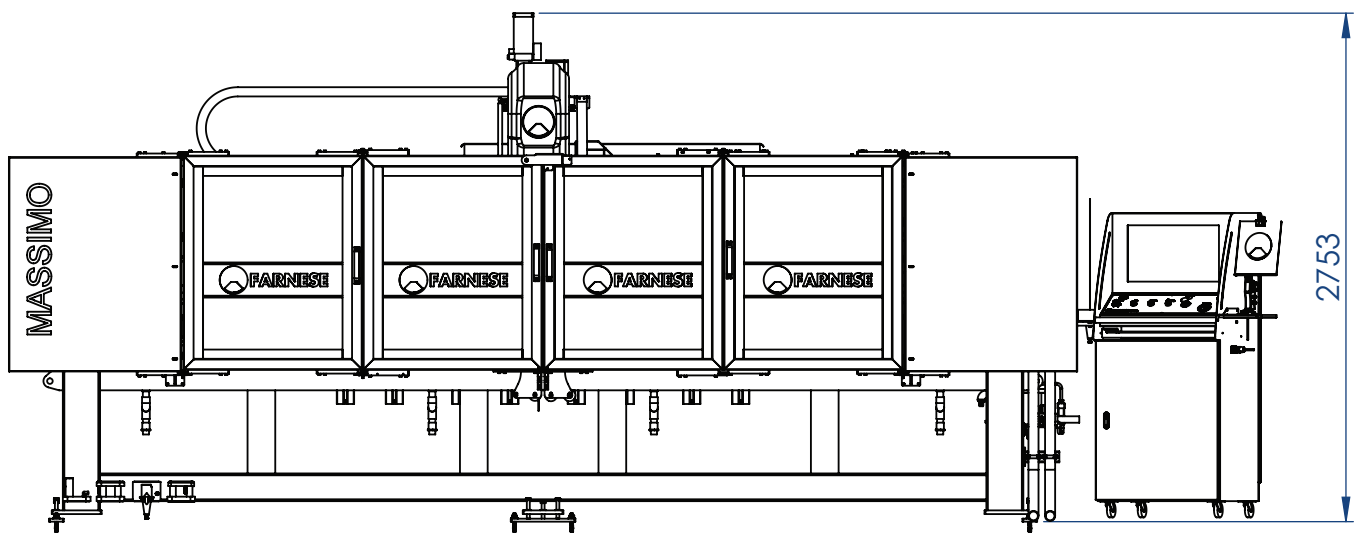
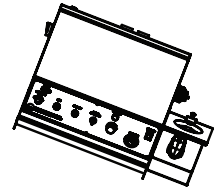
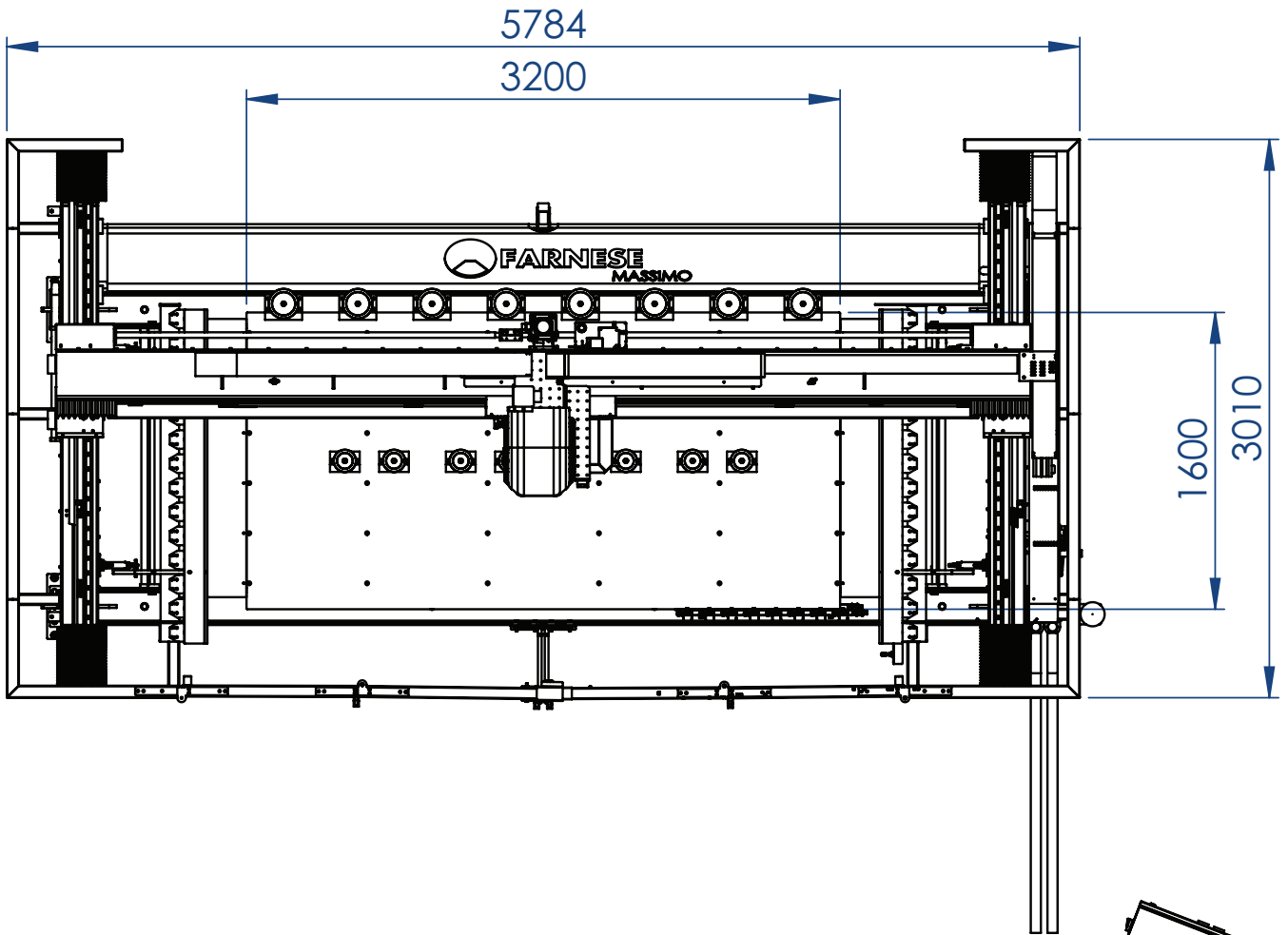

We Know That Support Is Important To You

Buying a new machine is a big commitment for anyone, and continued support throughout the life of that machine is vital.

Being an Australian and New Zealand company, we carry a vast array of parts here in New Zealand to ensure that your machine always has the spares it needs. Enjoy peace of mind knowing that you'll be fully supported by Farnese and we'll always have you covered.

Farnese customers don't need to experience unnecessary machinery downtime waiting for remote assistance from other countries, as all the support and remote assistance is provided locally in New Zealand from our own qualified Technicians in New Zealand time.

Our mission here at Farnese is to give you the best support. As we grow, we continue to recruit more and more qualified technicians, to further strengthen our position in the industry.

68 Montgomery Crescent, PO Box 40-809, Upper Hutt, New Zealand

PH +64 4 526 8589 info@farnese.co.nz