

# VACUUM LIFTER

Lift and handle slabs with ease

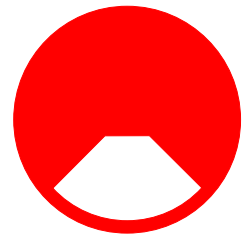

The VACUUM LIFTER combined with the JIB CRANE 360 gives you the perfect lifting system for all your large and small work.

This essential piece of equipment is fitted with a pneumatic tilting piston which provides complete control of vertical and horizontal positions. A continuous air supply combined with a Venturi system generates vacuum into 3 individual pads, allowing you to hold slabs up to 500kg (maximum) and is fitted with a gauge displaying the vacuum intensity.

This accessory is also equipped with a manual cleaning system, draining away accumulated water.

# VACUUM LIFTER

Lift and handle slabs with ease

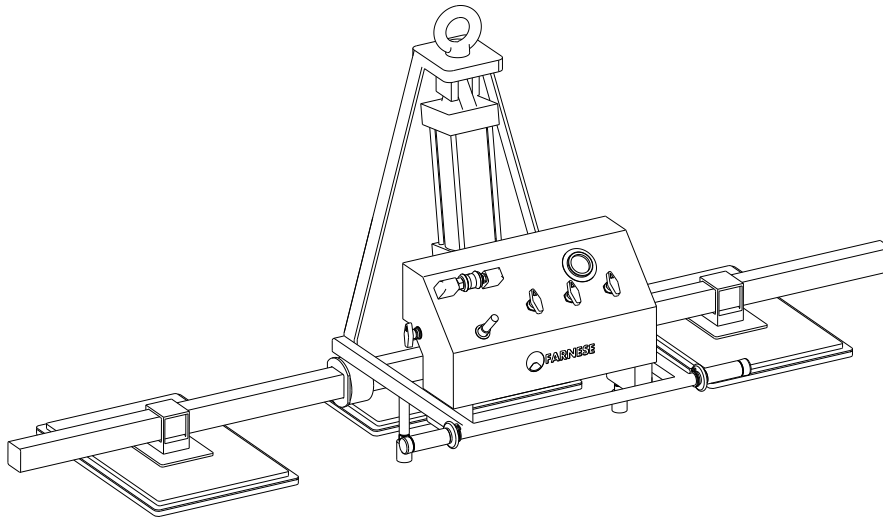
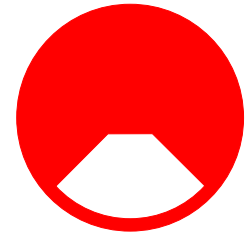

## TECHNICAL SPECIFICATIONS

### DIMENSIONS OF INSTALLED EQUIPMENT

WIDTH	2200 mm	86.6 in
DEPTH	780 mm	30.7 in
HEIGHT	850 mm	33.5 in
WEIGHT	100 kg	220.0 lb
LOAD (SAFE WORKING LIMIT)	400 kg	880.0 lb

### EQUIPMENT RANGES

AIR PRESSURE (WORKING)	7 bar	102 psi
AIR PRESSURE (CONSUMPTION)	350 litres/min	
CLEANING VALVE	YES	
VACUUM GAUGE	YES	
VACUUM GENERATOR	YES	
VACUUM PADS	YES	3 Pos

\*CONNECTIONS REQUIRED (SUPPLIED BY CUSTOMER)

POWER, WATER, COMPRESSED AIR.